

DuraVane^{HV}

High vacuum pumps down to 7.5×10^{-3} Torr*
RVR006M

DuraVane^{HV} high vacuum pumps (RVR-series):
Lubricated rotary vane pumps for operating in the pressure range of 7.5×10^{-1} down to 7.5×10^{-3} Torr*. (Partial final pressure range 3.8×10^{-1} to 3.8×10^{-3} Torr - McLeod). The pumps feature a compact design with very quiet operation (54-64dBA). Typical applications include refrigeration, air-conditioning and other high vacuum requirements.

- Heavy duty construction.
- Compact design, small footprint.
- Multi-frequency motor.
- Gas ballast valve is standard.
- Low noise level.
- Low maintenance.
- Air-cooled design.
- Direct drive.
- Simple to install.

* = Total final pressure unless otherwise specified.

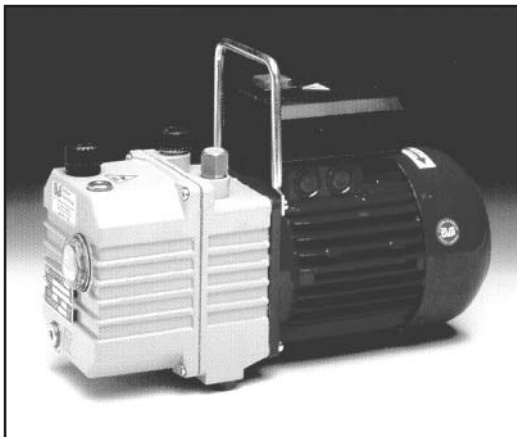

Performance characteristics

Number of stages:	1
Displacement:	6CFM
Final pressure:	7.5×10^{-2} Torr
Partial(McLeod):	3.8×10^{-2} Torr
with gas ballast:	2.3Torr
Motor:	0.5HP/50/60HzTEFC
Voltage:	115/230V/1phase
Speed:	1800RPM
Noise level(at 3ft):	54dBA
Oil reservoir cap.:	0.4qt
Oil type:	Duratex68
Weight:	28Lbs
Inlet conn.:	1/4"NPT

RVR006M

Based on 760 mm Hg (Torr) barometric pressure.
Inlet temperature 70° deg. F.

--- with gas ballast

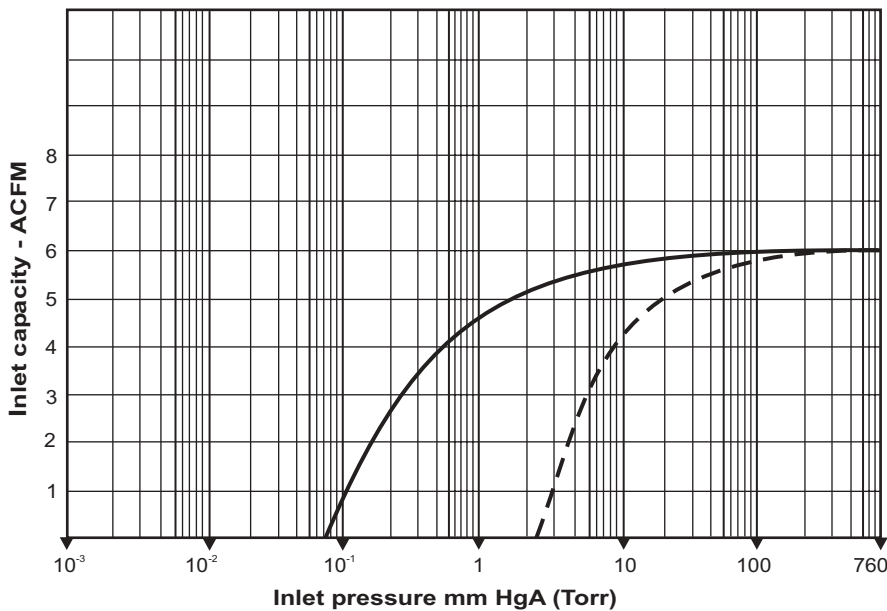

RVR006M

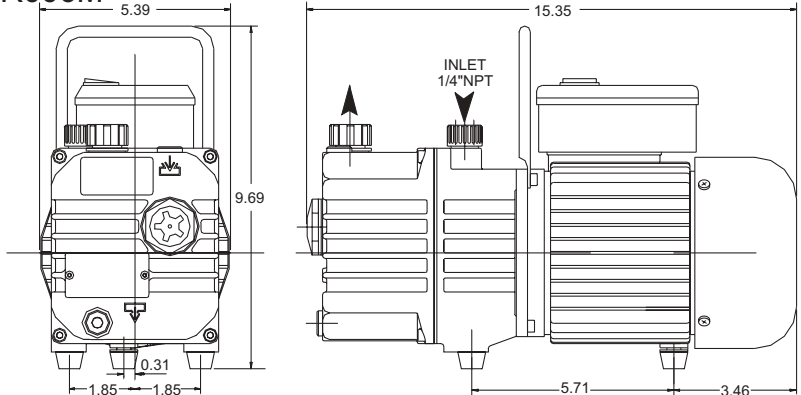

Information contained in this document is for reference only. Subject to change without notice.