

LACO TECHNOLOGIES

USER MANUAL



GASCHECK 3000/3000is

CONTACT US



PHONE/FAX

Toll Free: 800.465.1004

Phone: 801.486.1004

Fax: 801.486.1007

ADDRESS

LACO Technologies, Inc.
3085 West Directors Row
Salt Lake City, UT 84104

WEB

www.lacotech.com

info@lacotech.com

TECHNICAL SUPPORT AND SERVICE

support@lacotech.com

Declaration of conformity

Manufacturer: Ion Science Ltd, The Way, Fowlmere, Cambridge, England. SG8 7UJ

Product: GasCheck 3000 (Grey Case)

Product description: a handheld micro thermal conductivity sensor used to detect gas leaks. This has been designed specifically for search and location of non-flammable gases such as helium and CFC's.

Directives: 89/336/EC EMC

Standards:	BS EN 61010-1:2001	Safety requirements for measurement, control & lab equipment
	BS EN ISO 9001:2000	Quality management systems
	BS EN 61326-1:1997	EMC – Equipment for measurement, control and laboratory use

Signed By:



Name: Mark Stockdale,
Position: Technical Director
Date: 23rd April 2007

Safety: GasCheck complies with the requirements of 73/23 EEC low voltage directive and, apart from a low voltage pump, there are no moving parts within the instrument so that the machinery directives are not applicable.

Declaration of conformity

Manufacturer: Ion Science Ltd, The Way, Fowlmere, Cambridge, England. SG8 7UJ

Product: GasCheck 3000is (Black Case) (intrinsic version only)

Product description: an intrinsically safe handheld micro thermal conductivity sensor designed specifically for use in potentially explosive atmospheres and for the search and location of flammable gas leaks.

Marking:  II 2 G Baseefa 02ATEX0093 EEx ia IIC T4 $-20^{\circ}\text{C} \leq T_a \leq +60^{\circ}\text{C}$

Notified body: ATEX: Baseefa 2001 Ltd, Rockhead Business Park, Staden Lane, Buxton, Derbyshire, SK17 9RZ

Notified body No: EC1180

Directives: 94/9/EC ATEX 100A
89/336/EC EMC

Standards: BS EN 13908:2002	ATEX – Application of quality systems
BS EN 50014:1998	ATEX – general requirements
BS EN 50020:2002	ATEX – Intrinsic safety "i"
BS EN 61010-1:2001	Safety requirements for measurement, control & lab equipment
BS EN ISO 9001:2000	Quality management systems
BS EN61326-1:1997	EMC – Equipment for measurement, control and laboratory use

Signed By:



Name: Mark Stockdale,
Position: Technical Director
Date: 23rd April 2007

Safety Rating: This intrinsic safety rating permits its deployment in all potentially explosive atmospheres of the quoted (or less demanding) rating. That is, in areas where explosive gases (of Group IIA, IIB and IIC) are intermittently present (Zone 1), within an ambient temperature range of -20°C and $+60^{\circ}\text{C}$.

GasCheck complies with the requirements of 73/23 EEC low voltage directive and, apart from a low voltage pump, there are no moving parts within the instrument so that the machinery directives are not applicable.

CONTENTS	Page
1. Introduction	5
1.1 Scope & definitions	5
1.2 Description	5
1.3 Principle	5
1.4 Applications	6
2. Technical data	7
2.1 General	7
2.2 Performance	8
2.3 Battery data	9
3. Packing list	10
4. Operation	11
4.1 Controls	11
4.2 Display	13
4.3 Audio & Visual outputs	14
4.4 Prepare the GasCheck	14
4.5 Switch on the GasCheck	16
4.6 Recommended leak search	16
4.7 Switch off the GasCheck	17
5. Maintenance	17
5.1 Inspect and Clean the GasCheck	17
5.2 Replace the Batteries	18
5.3 Fault finding	20
6. Storage & Disposal	20
6.1 Storage	20
6.2 Disposal	20
7. Spares and Accessories	21
7.1 Introduction	21
7.2 Spares	21
7.3 Accessories	21
7.4 Calibration	21
7.5 Refurbish program	21
8. Instrument Service and Warranty	22

1 INTRODUCTION

1.1 Scope and definitions

This manual provides installation, operation and maintenance instructions for the GasCheck 3000 and 3000is. You must use the GasCheck as specified in this manual.

Read this manual before you install and operate the GasCheck. Important safety information is highlighted as WARNING and CAUTION instructions; you must obey these instructions. The use of WARNINGS and CAUTIONS is defined below.

WARNING
Warnings are given where failure to observe the instruction could result in injury or death to people.

CAUTION
Cautions are given where failure to observe the instruction could result in damage to the equipment, associated equipment and process.

The units of measurement used throughout this manual conform to the SI international system of units of measurement

1.2 Description

Refer to Figure 1. The GasCheck is a portable, battery-powered, hand-held gas leak detector. Indications of a leak are shown on the digital display (2) and are also given by a front panel mounted LED flasher (3) and as audible clicks from the rear panel loud speaker (6). Two versions of GasCheck 3000 are available:

- The standard GasCheck 3000 - suitable for leak detection of all non-flammable gases other than air.
- The GasCheck 3000is - intrinsically safe and is suitable for leak detection of hydrogen and other flammable gases, and for leak detection in hazardous areas of EEx ia IIC T4 rating.

The GasCheck has a convenient storage and carrying case, together with a spare battery holder, a long flexible probe (for leak detection in areas where access is restricted) and a box-spanner for probe changing.

1.3 Principal of operation

When the GasCheck is switched on, a small internal fan draws gas samples through the probe and into the GasCheck. The GasCheck measures the thermal conductivity of the gas samples.

When you first switch on the GasCheck (or when you press the manual zero key: see Section 4.1), an auto zero is made. If further samples have a different thermal conductivity from the zeroed sample, the Gas Check calculates and displays the difference as a leak rate.

This means that you can use the GasCheck to detect any gas other than that in which the Gas Check is zeroed.

1.4 Applications

You can use the GasCheck on many types of applications, including those listed below.

- Quality assurance testing on manufactured component seals.
- Laboratory applications, such as the detection of leaks from gas chromatographs, from mass spectrometers, from gas cylinders and fittings.
- Industrial applications, such as the detection of leaks from gas installations, in cylinder receiving rooms, from pipeline assemblies, the detection of leaks from stored gases and the detection of vapours released from stored chemicals.
- Medical applications, such as the detection of leaks from anaesthetic gas bottles and pipelines and leak testing of membrane materials, glove boxes and so forth.
- Valve emission evaluation to EPA (Environmental Protection Agency) method 2.1
- Leak testing of pipeline joints, gaskets, chamber windows and so forth

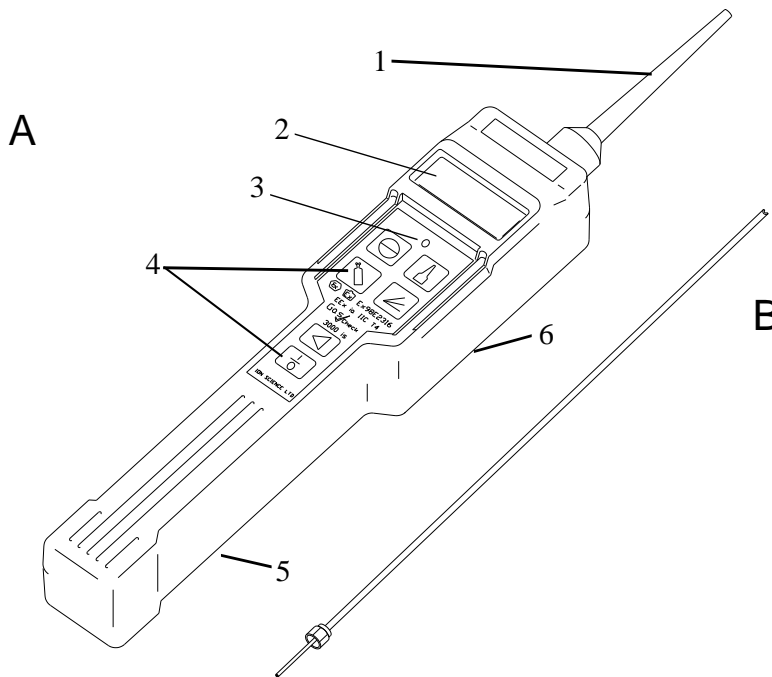

A Gas Check with short probe and nozzle fitted

B Long probe

- | | | | |
|---|-------------|---|---------------------|
| 1 | Nozzle | 4 | Tactile keys |
| 2 | Display | 5 | Battery compartment |
| 3 | LED flasher | 6 | Loudspeaker |

Figure 1 – The GasCheck 3000 and 3000is

2 TECHNICAL DATA

2.1 General

Operating temperature range

GasCheck 3000	0 to 50 °C	32 to 122 °F.
GasCheck 3000is	-20 to +60 °C	-4 to 140 °F.

Storage temperature range

-25 to 70 °C	-13 to 158 °F.
--------------	----------------

Materials of construction

Storage case	Polypropylene with polyester foam insert
GasCheck	Polyurethane casing on 3000 only Conductive polypropylene resin with metal bracket on 3000is only

Dimensions

Storage case	420 x 320 x 97 mm	16.5" x 12.5" x 3.75"
GasCheck	see Figure 2	

Mass

Complete storage case	1.6 kg	3.5 lb.
GasCheck	0.5 kg	1.0 lb.

Ingress ratings

Minimum	IP20
---------	------

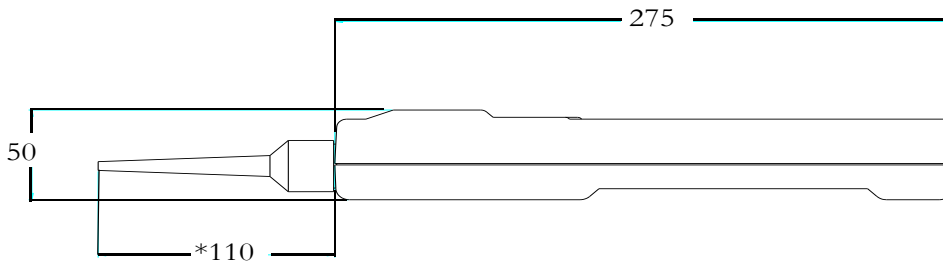

* Length of short probe and nozzle. Length of long probe = 300 mm (12")

Figure 2 – Dimensions (mm)

2.2 Performance

Detector type: Dual micro-volume thermal conductivity cell

Gases Detected:

All gases and vapours having a different thermal conductivity to the ambient air on which it was zeroed. The larger the difference the greater the sensitivity, so that GasCheck is not highly sensitive to the gases normally found in large concentrations in the ambient air, e.g. N2 (nitrogen) and O2 (oxygen).

For ease of use the GasCheck groups gases having similar thermal conductivity into one of the 5 gas groups shown in Table 1. Each group has a calibration curve stored in memory. Although the GasCheck will detect ALL gases with a different thermal conductivity to air, Table 1 lists those 12 common tracer gases that have been tested and assigned gas groups. If the gas or gas mixture that you seek is not included in these groups, select group 0 (which is the most sensitive). The Gas Check will then still find leaks quickly even though the measured values will not be displayed accurately. Some gases give a negative response, among them argon (Ar) carbon dioxide (CO₂) and R134a.

Minimum response time:

Short probe fitted	Less than 1 second
Long probe fitted	About 9 seconds

Recovery time

Maximum detection level with the short probe and nozzle fitted	About 1 second
The nozzle when fitted provides automatic 10-fold dilution of the gas stream entering the detector cell.	20 ml/sec

Smallest leak detection levels: see Table 1 (below)

Note1: *the minimum detection levels given in Table 1 apply when the Gas Check is used in clean laboratory air conditions. When used in conditions where the ambient atmosphere contains clouds of the gas for which you leak test, the minimum detection levels may be obscured.*

Note2: *An offset of up to 10 times the detection levels given in Table 1 may be experienced in the presence of electromagnetic interference @ 320 +/- 30 MHz at the levels specified in EN 50082-1.*

Table 1- Smallest Leak Detection Levels

Gas Gas Group Positive/Negative	Smallest Leak Detection Level in ml/sec
H₂	1.5 x 10 ⁻⁵ ml/sec
He	2.0 x 10 ⁻⁵ ml/sec
R12	5.4 x 10 ⁻⁵ ml/sec
R1301	4.9 x 10 ⁻⁵ ml/sec
R134a	2.1 x 10 ⁻⁴ ml/sec
R22	5.1 x 10 ⁻⁵ ml/sec
SF₆	4.4 x 10 ⁻⁵ ml/sec
CO₂	8.0 x 10 ⁻⁵ ml/sec
CH₄	5.8 x 10 ⁻⁵ ml/sec
Ar	7.0 x 10 ⁻⁵ ml/sec
R11	6.3 x 10 ⁻⁵ ml/sec
O₂	5.7 x 10 ⁻⁴ ml/sec

2.3 Battery data

Note: The energy storage capacity of batteries is affected by temperature. The data in Table 2 is for an ambient temperature of 20 °C (68 °F).

WARNING

For GasCheck 3000is

Do not modify the GasCheck 3000is equipment to allow any recharging.

For Intrinsic Safety T4 Rating in the Gas Check 3000is rechargeable batteries (e.g. Ni-Cad) must not be used.

There is no provision for the recharging of batteries within the GasCheck 3000is.

For alkaline types (MN1500 or LR6) type use only Duracell (Standard, Procell or Ultra) or Ever Ready (Energiser) batteries. Alternatively use any zinc carbon types R6PP or R6S

For GasCheck 3000

Do not modify the GasCheck 3000 equipment to allow any recharging

Do not use in a hazardous area. Use the GasCheck 3000is.

The GasCheck 3000 is designed for use with primary (disposable) batteries.

Number of batteries required	4
Battery type	Alkaline, size AA
Recommended batteries	LR6 (R6) or MN1500
Average operating life	see Table 2

Battery type	Battery life (hours)	
	Gas Check 3000	Gas Check 3000is
LR6 (R6) *	40	20
MN1500 *	40	20
R6S	20	10
R6PP	20	10

* Preferred battery types

Table 2 – Average battery life

The use of the back light will dramatically shorten the battery life.

Do not change batteries in a hazardous area – see section 5.2.

3 PACKING LIST

Remove all packaging materials, then open the storage case and inspect the equipment. If the storage case or any other item is damaged, notify your supplier and the carrier in writing within three days; state the Item Number and the Serial Number stamped on rear case of the GasCheck, together with your order number and your supplier's invoice number. Do not use the GasCheck if any item is damaged.

Refer to Figure 3 and check that the storage case contains the items listed in Table 3. If any item is missing, notify your supplier in writing within three days.

Qty	Description	Check ()
1	Gas Check (with short probe and nozzle fitted)	
1	Long probe	
1	Box-spanner	
1	Special screwdriver for access to battery compartment (Gas Check 3000is only)	
1	Spare battery holder with 4 batteries	

Table 3 – Checklist of items in the storage case

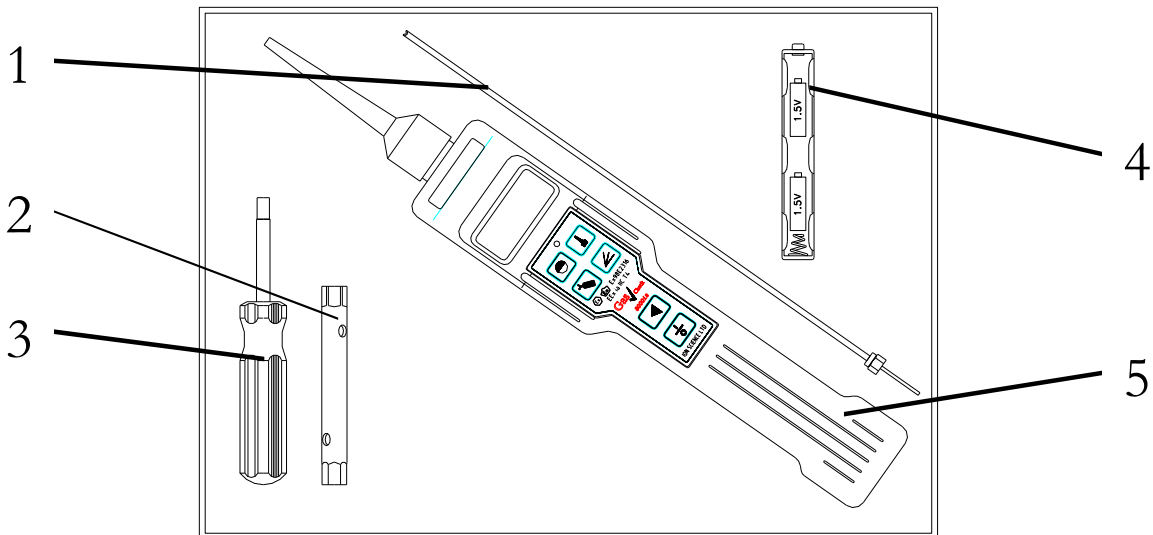

- | | |
|--------------------------|---|
| 1. Long probe | 4. Spare battery holder |
| 2. Box-spanner | 5. Gas Check (with short probe and nozzle fitted) |
| 3. Special screwdriver * | |

- Gas Check 3000is only

Figure 3 – Items in the storage case

4 OPERATION

4.1 Control buttons

Refer to Figure 4. Use the control keys as described below. The display symbols are described in Section 4.2.2.



POWER (1) Press this key to switch the GasCheck on and off.



ZERO (2) Press zero to adjust for background levels, reset the peak hold memory or after changing a gas group or a leak range as required.



GASES (3) Press and hold the gas key to scroll through the common gases and Gas Groups of the GasCheck (shown in Table 4 below). Release when your chosen gas is showing in the lower portion of the display. The GasCheck display should be zeroed to maintain the calibration.



BACKLIGHT/CONTRAST (4) Press the Contrast key once to switch ON Back-light for a pre-set period (20 seconds). Press and hold this key to change the contrast setting. The message on the display will then show whether contrast drive is to darken or lighten the display. There may be little or no need to use this control at normal temperatures.



NOZZLE/PEAK HOLD (5) When the GasCheck is applied to leak location in the presence of large leakage, the nozzle is very useful. The nozzle symbol when displayed corrects the leak rate range accordingly. Calibration is performed without it. Press and hold the nozzle key to scroll through the nozzle and peak hold options. Release when desired. Peak hold function displays the value and range indicators for the maximum signal. Press Zero to reset this. Note that the audio follows the detected signal even when the signal falls below the stored peak hold value.



RANGE (6) Range may be selected to concentrate on significant leakage levels only rather than Auto range all leakage. When auto range is selected the display shows the auto range symbol in the lower portion. Where necessary hold down the key to select a fixed less sensitive range rather than Auto-range in order to restrict the leak response. The auto range symbol will not appear on the display if auto range is not selected.

Gas	Gas Group	Positive/Negative
H₂	0	Positive
R12	0	Negative
R1301	0	Positive
R134a	0	Negative
He	1	Positive
SF₆	1	Negative
R22	1	Negative
CO₂	2	Negative
CH₄	2	Positive
Ar	2	Negative
R11	3	Positive
O₂	4	Positive

Table 4 – Gas Groups

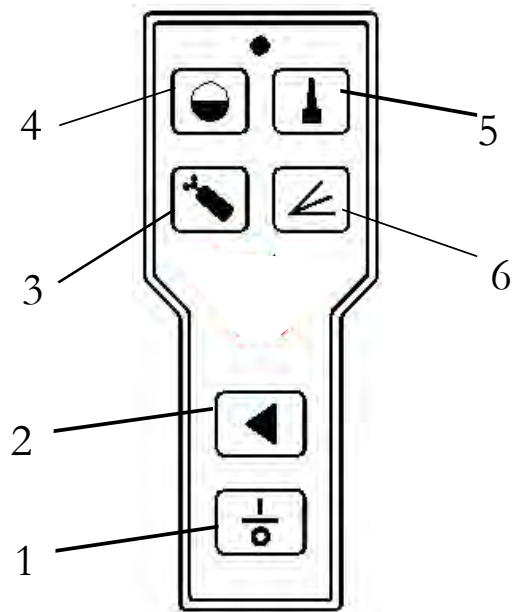

1 Power



2 Zero



3 Gases



4 Backlight/Contrast



5 Nozzle/Peak hold



6 Range



Figure 4 – Control keys (layout shown for both Gas Check 3000 and 3000is)

4.2 Display

4.2.1 General

The display is arranged to show the leak rate and other status including user changes to the settings.

- In normal use the upper portion of the display is used for a large size digital representation of the leak rate (see Section 4.2.2) and status information is shown as symbols (see section 4.2.3) appearing in the lower portion. The Gas Group or the gas chosen will show on the lower right hand side of the display.
- In response to key presses, written text will appear confirming the changes to settings.

Examples are

Zeroing detector

Nozzle On

Peak hold On

Nozzle off

Peak hold off

He

Group 0

Contrast darker

Contrast lighter

4.2.2 Leak rate indication

Leakage is displayed as a single (signed) digit x 10 (signed) range for ease of interpretation and calibration. [Note that some gases (e.g. CO₂ and R134a) may cause a negative leak indication after GasCheck zeroing in clean air. See the Positive/Negative column in Table 4]

Examples are

Leak rate for a positive gas: 5 x10⁻⁵ ml / s

Leak rate for a negative gas: - 3 x10⁻⁴ ml / s

4.2.3 Other display symbols

Small display indicators show zeroing, nozzle fitted, peak hold, auto range and low battery voltage.

Zeroing

This symbol appears whilst the GasCheck is zeroing then it disappears.



Auto range

This symbol shows when the GasCheck leak rate is not fixed within one range.



Nozzle

This symbol indicates that the GasCheck is being used with the Nozzle on.



Peak hold

This symbol indicates that the GasCheck display is held to the maximum.



Low battery

This symbol indicates that the battery pack is lower than required for use.



Negative

This shows the leak rate signal is negative (valid for testing some gases, see Table 4).



4.3 Audio and visual outputs

The GasCheck has an internal audio sounder and a flashing LED indicator.

They both operate together when the detected leak rate climbs from the zero indication towards the maximum on the leak rate range (see Section 4.2.1). They also operate once to confirm a key press.

4.4 Prepare the GasCheck

4.4.1 Select which probe to use

Note: Whenever possible, use the Gas Check with the nozzle fitted. The nozzle helps to protect the short probe from blockage or damage. You cannot use the nozzle with the long probe.

Open the storage case and remove the Gas Check. The Gas Check is supplied with the short probe fitted and the nozzle fitted; a long probe is supplied in the storage case. Standard use is with the short probe and nozzle. For higher sensitivity, remove nozzle and clear the nozzle symbol from the display (section 4.1).

Determine whether you want to use the short probe or the long probe and whether you want the nozzle fitted, as follows:

Use the Gas Check with the short probe and without the nozzle to detect small leak rates of approximately 1×10^{-4} ml/sec and lower. Press the nozzle key to clear the nozzle fitted indicator: refer to Section 4.1

The nozzle simply pulls off and pushes onto the end of the Gas Check. To remove the nozzle or to change the probe, refer to Section 4.4.2.

4.4.2 Remove the Gas Check nozzle or change the probe (if required)

In some applications the grey probe cover may restrict access to the area under test, the grey probe cover can be removed by pulling it off way from the instrument **1**. When the grey cover is removed great care should be taken when using the instrument and the following precautions noted:-

- * Do not remove the semi transparent probe sleeve, this sleeve ensure the metal inner probe remains 1 mm from the surface of the test area avoiding accidental dirt and moisture ingress.
- * Do not touch the probe and especially the brass sensor housing. Heat from fingers can result in significant changes in signal causing false readings.
- * Avoid placing the probe on wet or dirty surfaces, blockage of the probe will result in instrument failure.

Some application may require a longer probe to gain access to pneumatic joints and seams to be tested, the GasCheck is also supplied with a 300mm probe that can be changed by the user. To change probes carefully follow the following steps:-

- * Switch the instrument OFF
- * Remove the outer grey probe cover **1**
- * Place the box spanner (supplied with the instrument) over the existing probe so the spanner fits over the brass nut **2**, unscrew the probe counter-clockwise direction. **3**
- * Withdraw the spanner and probe assembly **4**

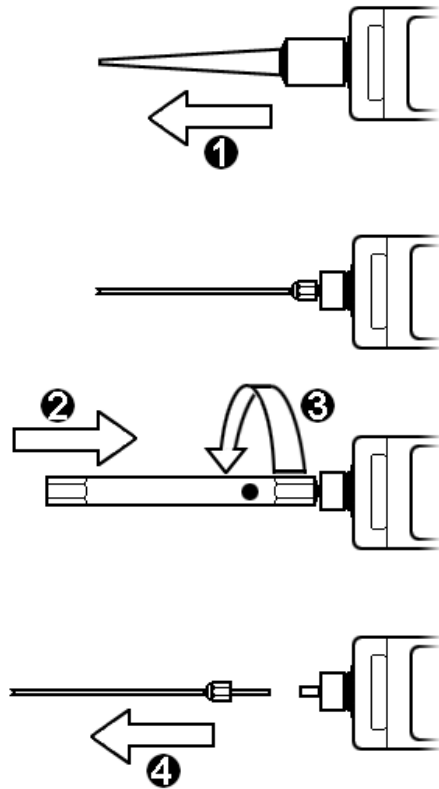

To refit the short or the long probe follow the steps above but in reverse order.

CAUTION: When using the box spanner to tighten the probe nut, ensure the nut is firmly tightened however do not use additional tools as the tread may become damaged.

Should a probe become blocked, use dry, clean compressed air to blow out the blockage from the instrument end of the probe.

Cautionary Note: The instrument has been factory calibrated using the standard short capillary which sets a certain flow rate into the detector.

The long capillary by nature of its construction has a different flow to improve the time response in detection. This will change the calibration of the instrument when the long probe is used instead of the short capillary. Thus the long probe is only to be used in finding leaks in difficult places where the standard short probe cannot reach. The readings given by the long probe are only qualitative and the reading given by the display is only to be taken as being relative to another value given by another leak site while using the long probe.

WARNING: Ensure safety guidelines are adhered to when using compressed air.
(Ion Science Ltd takes no responsibility for injury or damage caused by misuse of compressed air equipment)

4.5 Switch on the Gas Check

Press key and wait for GasCheck to bleep & flash, the display to light up and show "zeroing detector". When not detecting leaking gas, GasCheck still flashes and beeps periodically to indicate that it is ON.

GasCheck remembers the settings on instrument power off so that the operator rarely if ever has to alter any of them. The settings for gas group, auto range, peak hold and nozzle are shown on the display.

The response of GasCheck can readily be checked against an Ion Science CalCheck traceable calibration accessory.

4.6 Recommended leak search procedure

4.6.1 General procedure

Note: When you use the GasCheck, do not allow dirt or debris to enter the end of the probe or nozzle. If the probe or nozzle is blocked, the GasCheck will not operate correctly.

The following test procedures assume that you have fitted the short probe. The response time of the GasCheck increases from about 1 second or less when the short probe is fitted to about 9 seconds when the long probe is fitted. If you use the long probe for leak detection, ensure that you move the end of the probe much more slowly along the area you leak test.

Ensure the part under test contains a reasonable percentage of a trace gas that is different from normal air!

Move the end of the probe (or nozzle) around the area of a suspected leak and look at the display (or listen to the audible clicks or note the visual LED flash rate on the GasCheck) to identify the location of a leak. Specific procedures for leak detection along seams and around pipe joints are described in the following sections.

When required:

- Use the peak hold and Auto-Ranging modes to continue to check for leaks, but to display the largest leak detected
- If you want to zero the GasCheck, move the end of the probe (or nozzle) away from any possible leak, into a clean air zone, then press the manual zero key: refer to Section 4.1.

Note that leak sensitivity depends on the ambient conditions. If you want to accurately measure a leak, compare the indicated leak with a calibration standard, such as a CalCheck: see Section 7.3.

When the GasCheck indicates that a leak has been found, move the probe (or nozzle) back to determine the precise location of the leak. The leak is located where the largest leak size is indicated on the display and where highest frequency clicks and visual flashing rate are emitted by the GasCheck, on the current range.

4.6.2 Leak detection along seams

Move the end of the GasCheck probe (or nozzle) along the length of the seam, so that it just rests on the seam. The speed at which you move along the seam depends upon the size of the leak that you search for:

- If the leak is large, you can move fairly fast along the seam, at approximately 25 mm per second.
- If the leak is small, move slowly along the seam, at approximately 10 mm per second.

4.6.3 Leak detection at pipe joints

Use the same procedure as for leak detection along seams (see Section 4.6.2), however, move the probe (or nozzle) around the joint at approximately half the speed specified in Section 4.6.2. Light gases (such as hydrogen and helium) diffuse quickly into air, so an apparent leak on the side or top of a joint may actually be a leak at the bottom of the joint.

4.7 Switch off the GasCheck

When the GasCheck 3000 has been left for a few seconds without any key press, then press the I/O key. The GasCheck will ignore I/O presses during the instrument power up sequence and during any zeroing.

4.7.1 Auto Shut Off

If the GasCheck is left for a period of approximately 10 minutes without key presses it will shut itself off.

5 MAINTENANCE

5.1 Inspect and clean the GasCheck

CAUTION

Do not clean the probe while it is attached to the GasCheck and do not try to clean the sample hole

1. Switch off the GasCheck.
2. Refer to Figure 5. If the nozzle is fitted, hold the nozzle (1) by its wide base and gently twist and pull it to remove it from the GasCheck.
3. With the small end of the box spanner towards the GasCheck, guide the end of the probe (2 or 7) through the middle of the supplied box spanner. Push the box spanner onto the nut (3) and turn the box spanner anticlockwise to undo and remove the probe.
4. Inspect the GasCheck. If the case of the GasCheck is cracked or dented, we recommend that you do not continue maintenance, but return the GasCheck to your supplier for inspection and calibration.
5. Wipe the GasCheck with a clean, lint-free cloth moistened with a weak solution of detergent.
6. Carefully wipe the outer faces of the probe/nozzle fitting to remove any small particles of dirt or debris.
7. Use a suitable tool to push any blockage out of the end of the nozzle, and then wipe the outside of and the inner face of the wide part of the nozzle.
8. Inspect the probe:
 - The hole in the short probe is approximately 0.47mm (0.0185inches) in diameter. We recommend that you push stiff wire of 0.25mm (0.01inches) diameter or less into the hole in the probe to remove any blockage.
 - The long probe is too long to be effectively cleaned. If the probe is blocked, we recommend that you obtain a new probe, available as a spare: refer to section 7.
9. Refit the required probe to the GasCheck: refer to Steps 4 to 6 in Section 4.4.2.
10. Place a light wipe of thin petroleum jelly around the inner face of the wide part of the nozzle, then fit the nozzle to the GasCheck.
11. Place the GasCheck and nozzle (and the long probe, if just removed) in its storage case. Store the case in suitable conditions: refer to Section 6.1.

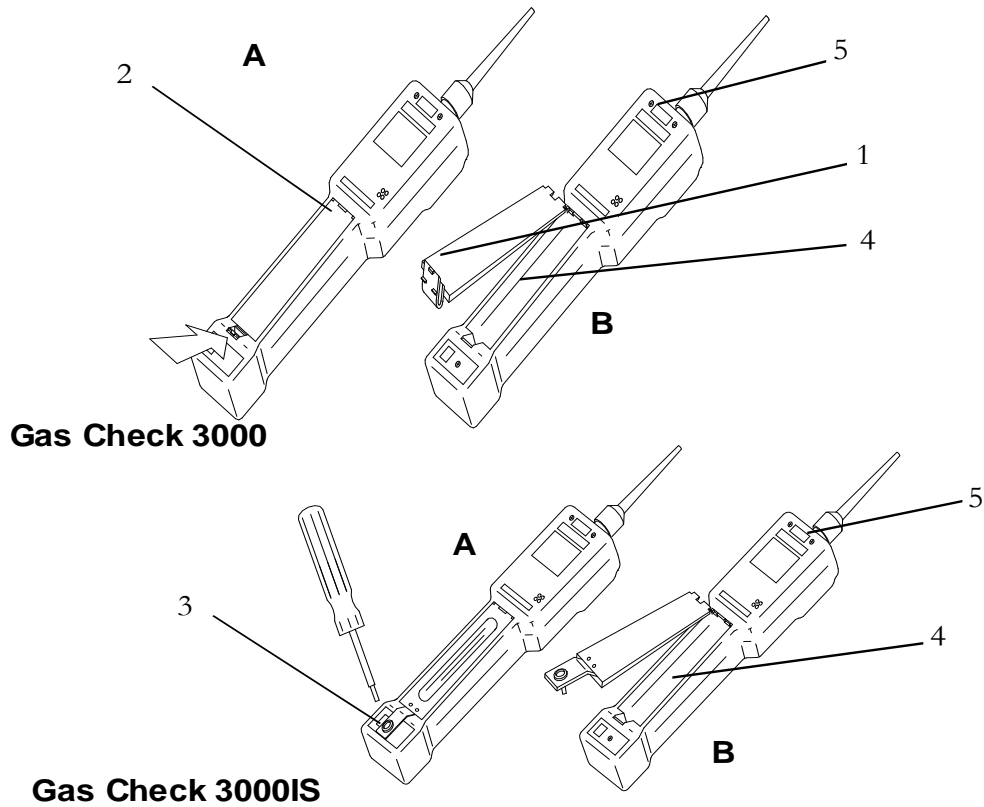

- | | | | |
|---|--------------------------------------|---|---------------------|
| 1 | Catch | 4 | Battery compartment |
| 2 | Battery compartment cover | 5 | Serial number |
| 3 | Captive screw location (3000is only) | | |

Figure 6 – Replace the batteries (GasCheck 3000 and 3000is shown)

5.2. Replacing the batteries

WARNING
Replace the batteries in the Gas Check 3000is in a safe area where there are no flammable gases. If you do not, there may be a risk of fire or explosion.

WARNING
Use only dry cell (non-rechargeable) batteries in the GasCheck 3000is. The internal resistance of rechargeable batteries is too low to maintain a T4 safety rating. The recommended batteries are specified in section 2.3 Battery Data.

CAUTION

Ensure that the rubber sleeve on the female part of the battery holder is correctly fitted when you fit new batteries. If you do not, you could refit the holder in the GasCheck 3000is with incorrect polarity which will damage the GasCheck 3000is.

Note: A spare battery holder is supplied with the GasCheck.

1. Refer to Figure 6. Turn over the GasCheck so that the battery compartment is at the top: see detail A.
2. On the GasCheck 3000, use a small coin, screwdriver or your fingernail to press the catch (1) on the battery compartment cover (2), then pull up and remove the cover: see detail B.
On the GasCheck 3000is, use the special screwdriver supplied to undo the captive screw on the battery compartment cover and remove the cover. This is located at the end of the GasCheck at position (5).
3. Remove the battery holder from the GasCheck. If required, you can carefully unplug the battery holder so that you can detach the holder from the GasCheck.
4. Remove the old batteries (4) from the battery holder. Dispose of the batteries (see section 6.2).
5. Inspect the inside of the battery compartment and battery holder. If the batteries have leaked, use a cloth dampened with a weak solution of detergent to clean the battery compartment and battery holder.

CAUTION

The GasCheck 3000is will blow a factory fitted internal protection fuse if the battery clip is inadvertently reverse connected. The complete instrument will have to be returned to the supplier for fuse replacement. The GasCheck 3000 has an internal self-resetting fuse. Please

6. Fit four new batteries in the battery holder. Ensure that you fit the batteries in the correct orientation. To reduce the risks of incorrectly connecting the battery clip remove one battery before you refit the battery holder to the GasCheck. You then add the fourth battery into the clip before pushing it into the battery compartment.
7. On GasCheck 3000, refit the battery compartment cover (2) and ensure that the catch (1) is engaged.

On the GasCheck 3000is, refit the battery compartment cover and use the special screwdriver to tighten the captive screw and secure the cover in place.

CAUTION

Ensure that the screw is located squarely to the threaded insert before tightening else the battery compartment cover may not be properly secured due to cross threading. The instrument will then have to be returned to the supplier for replacement of the GasCheck case including a new serial number.

8. Switch on the GasCheck to ensure that the batteries are correctly fitted. If the display remains blank when you switch on the GasCheck, refer to section 5.3.

5.3 Fault finding

Fault symptom	Diagnosis	Action
Unit will not switch on	No/dead batteries fitted	Try another battery set (safely)
Unit will not switch off	Software locked out	Remove & replace battery clip (safely)
Battery symbol appears	Battery state low	Replace batteries (safely)
Back light drains battery life	Excessive use of backlight	Avoid or reduce use of backlight
Unit will not zero	Software locked out by hardware	Remove & replace batteries (safely)
Display appears blank/dim	Contrast control setting wrong	Turn off & on; press & hold contrast
Numbers do not change	Peak hold selected	Press zero or change from Peak hold
Range does not change	Range not set in Auto-range	Press & hold Range until Auto-range
He range will not show -5	Unit with nozzle ON and/or range	Reset via Nozzle and Range keys
Gas group is wrong	Gas Group not set correctly	Press & hold Gases until shown OK
Nozzle/Peak not showing	Nozzle/Peak is not set correctly	Press & hold Nozzle until both correct
Blocked probe	Probe blocked	Remove probe and clean
Stalled motor	Motor failed & probe not blocked	Return to Ion Science for repair
Instrument readings noisy	Loose probe	Tighten nut slightly
Instrument readings noisy	Test environment contaminated	Move item under test into cleaner area
3000is unit will not turn on	Internal fuse blown	Return to supplier for repair

Table 5 – Fault finding

6 STORAGE AND DISPOSAL

6.1 Storage

If you will store the unit for a long time, we recommend that you remove the batteries: refer to Section 5.2

Refit the GasCheck in its storage case and store in dry, cool conditions. Unpack as described in Section 3.

6.2 Disposal

Dispose of the GasCheck, components and used batteries safely in accordance with all local and national environmental safety requirements. Some of the GasCheck carry case plastic material is recyclable.

7 SPARES AND ACCESSORIES

7.1 Introduction

Order spare parts from your local agent or distributor; when you order, please state for each part required:

- Serial Number on the back of your GasCheck (refer to Figure 6.)
- Item Number and description of part.

7.2 Spares

Spare	Item Number
Long probe	A-08045
Short probe	A-08043
Replacement battery holder 3000	SPGC8055
Replacement battery holder 3000is	A- 08139
Nozzle 3000	08024CFC8
Nozzle 3000is	08024CPC0
Box Spanner	A-08029
3000is screwdriver	4/TS-01
Case	31164
Instruction Manual	28052

7.3 Accessories

Accessory	Item Number
CalCheck - specifying gas, leak rate and pressure	A-21500

7.4 Calibration

Ion Science offers a calibration service including issue of traceable certification to National Standards.

7.5 Refurbish program

Ion Science offers a refurbish service for all customer repairs.

8 INSTRUMENT SERVICE AND WARRANTY

Warranty

Standard Warranty can be extended to up to 2 years on the GasCheck 3000 & 3000IS when registering your instrument via our website: www.ionscience.com/instrument-registration

To receive your Extended Warranty, you need to register within one month of purchase (Terms and Conditions apply). You will then receive a confirmation email that your Extended Warranty Period has been activated and processed.

Full details, along with a copy of our Warranty Statement can be found by visiting: www.ionscience.com/instrument-registration

Service

Ion Science is pleased to offer a number of service options on our GasCheck 3000 & 3000IS product range that allow you to choose the instrument cover that best suits your needs.

At Ion Science we recommend that all of our gas detection instruments be returned for service and factory calibration once every 12 months.

Contact Ion Science or your local distributor for service options in your area.

[Find](#) your local distributor by visiting: www.ionscience.com

UPDATE LOG

Manual Version	Amendment	Date updated	Instrument Firmware	PC Software
GasCheck 3000 & 3000is V1.8	Gas Table updated	16/7/08	3000- V0.48 3000is- V4.16	N/A
GasCheck 3000 & 3000is V1.9	Log added to back of manual	9/1/09	3000- V0.48 3000is- V4.16	N/A
GasCheck 3000 & 3000is V2.0	Warranty added to cover Declaration Conformity updated page 2 Contents updated Instrument Warranty and Service added page 22	23/07/10	3000- V0.48 3000is- V4.16	N/A