

LACO TECHNOLOGIES

USER MANUAL



JP120VH / JP200V

CONTACT US



PHONE/FAX

Toll Free: 800.465.1004
Phone: 801.486.1004
Fax: 801.486.1007

ADDRESS

LACO Technologies, Inc.
3085 West Directors Row
Salt Lake City, UT 84104

WEB

www.lacotech.com
info@lacotech.com

TECHNICAL SUPPORT AND SERVICE

support@lacotech.com

CONTENTS

1. SCOPE	1
2. INSTALLATION	1
3. BASIC OPERATION	1
4. MAINTENANCE	2
5. TROUBLESHOOTING	4

1. SCOPE

This manual contains operation and maintenance information for JP120VH and JP200V oil-free piston vacuum pumps. Please identify the model number and serial number when ordering parts.

2. INSTALLATION

2.1 UNPACKING

Inspect the box and pump carefully for any signs of damage incurred in transit. Since all pumps are ordinarily shipped F.O.B. from our factory or regional warehouse, such damage is the normal responsibility of the carrier and should be reported to them.

2.2 INSTALLATION

Install the pump in a horizontal position on a level surface so that the pump is evenly supported on its rubber feet. The pump must be installed in a dry, well ventilated place, which is as free of dust as possible. Leave 12-18 in of space around the pump to allow proper cooling. Also, adequate ventilation must be provided for the fans, radiator, and motor.

Remove plastic plugs from the inlet and outlet port before operating pump. Pump may be damaged if plugs are not removed.

Never operate the pump outdoors in the rain or near an open flame.

2.3 ELECTRICAL CONNECTION

Check the voltage and frequency on the identification plate before starting the electrical power of motor. The standard thermal protector will trip automatically if the maximum permitted temperature is exceeded. The pump will re-start automatically when it is cooled down.

3. BASIC OPERATION

Only atmospheric air is permitted as working media. Do not evacuate corrosive liquid or vapor with the pump.

Dirt will damage the pump so always remember to use an inlet filter. After the pump has been stopped, air will gradually seep back into the evacuated spaces. If this is undesirable, it will be necessary to fit a check valve in front of the inlet port.

The standard pump can not start against a full vacuum.

Improper disassembly or repair will damage the pump. Only qualified personnel can do repair service.

The pump is maintenance-free. Do not lubricate any of the parts with oil, grease, or petroleum products nor clean with acids, caustics, or chlorinated solvents at any time. This can affect the service life of the pump.

4. MAINTENANCE

Figure 1: JP120VH Exploded View

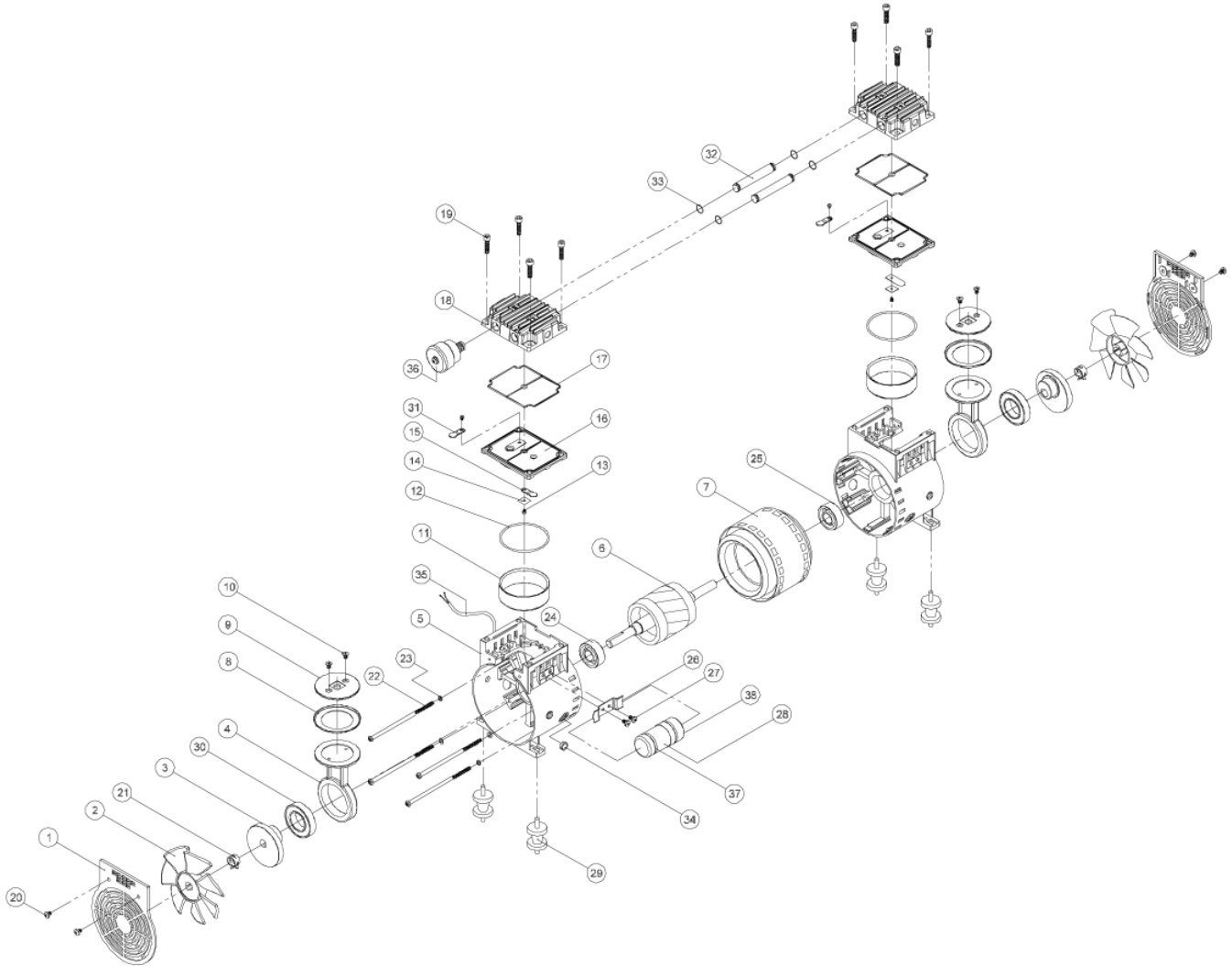

Table 1: JP120VH Parts List

POSITION	PART	DESCRIPTION
1	JP120-001	Front Cover
2	JP120-002	Cooling Fan
3	JP120-003	Eccentric
4	JP120-004	Piston rod
5	JP120-005	Housing
6	JP120-006	Rotor
7	JP120-007	Stator
8	JP120-008	Piston Cup Seal
9	JP120-009	Plate
10	JP120-010	Screw
11	JP120-011	Cylinder
12	JP120-012	O-Ring
13	JP120-013	Screw
14	JP120-014	Valve Fixed Strip
15	JP120-015	Valve
16	JP120-016	Valve Plate
17	JP120-017	Valve O-Ring
18	JP120-018	Head
19	JP120-019	Screw
20	JP120-020	Screw
21	JP120-021	Fixing Clamp
22	JP120-022	Bolt-Housing
23	JP120-023	Spring Washer
24	JP120-024	Bearing
25	JP120-025	Bearing
26	JP120-026	Bracket
27	JP120-027	Screw
28	JP120-028	Capacitor
29	JP120-029	Rubber Foot
30	JP120-030	Bearing
31	JP120-031	Valve
32	JP120-032	Connecting Tube
33	JP120-033	O-Ring
34	JP120-034	Cable fixing bracket
35	JP120-035	Electrical cable
36	JP120-036	Silencer
37	JP120-037	Fixed string
38	JP120-038	Capacitor protective cap

Figure 2: JP200V Exploded View

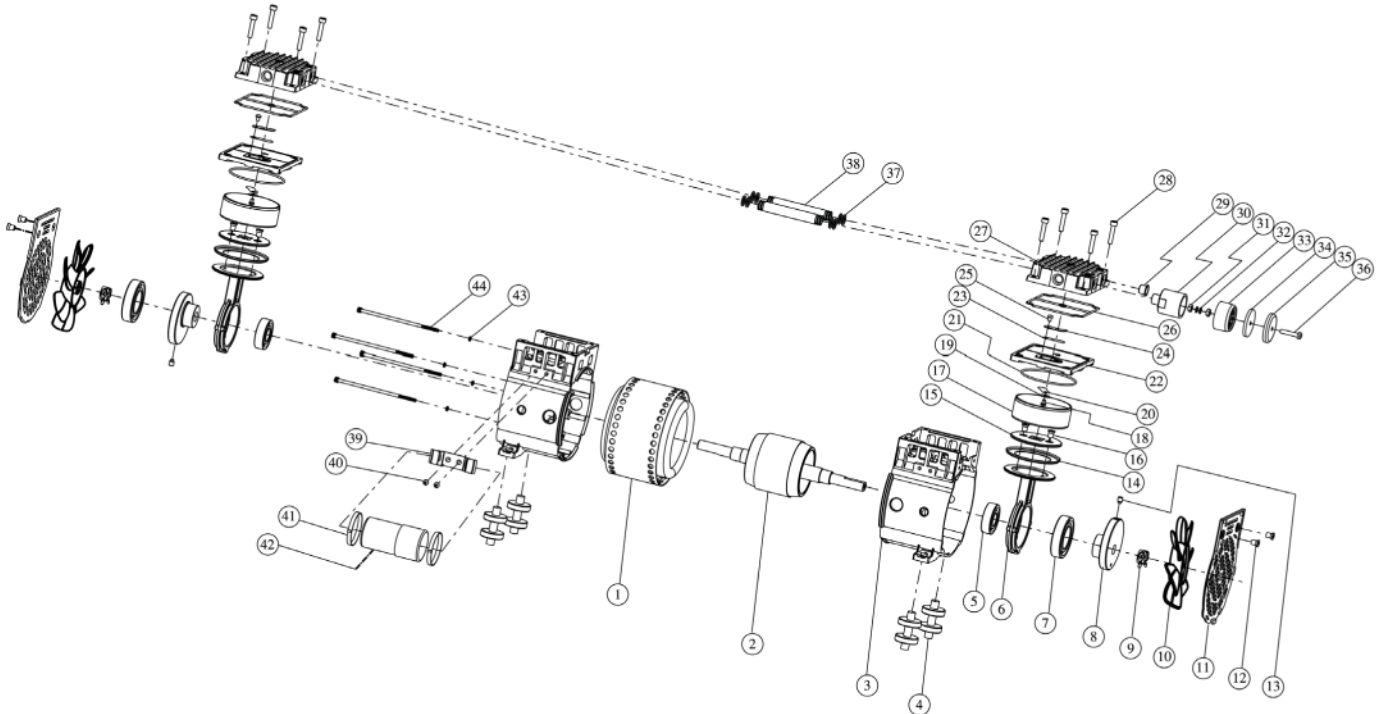

Table2: JP200V Parts List

POSITION	QUANTITY	DESCRIPTION
1	1	Stator
2	1	Rotor
3	2	Housing
4	4	Shockproof Foot
5	2	Bearing
6	2	Piston Rod
7	2	Bearing
8	2	Circle Eccentric
9	2	Fan Fixed Clamp
10	2	Cooling Fan
11	2	Cooling Fan Cover
12	4	Screw
13	2	Screw
14	2	Piston Ring
15	2	Piston Round Plate
16	4	Screw
17	2	Cylinder
18	2	Screw
19	2	Lower Valve Fixed Strip
20	2	Valve Flapper
21	2	Cylinder O-ring
22	2	Valve Plate
23	2	Valve Flapper

POSITION	QUANTITY	DESCRIPTION
24	2	Upper Valve Fixed Strip
25	2	Screw
26	2	Valve O-ring
27	2	Head Cover
28	8	Screw
29	1	PP Plug
30	1	Silencer base
31	2	Nut
32	2	Spring Washer
33	1	Silencer Top Cover
34	1	Silencer Cotton
35	1	Silencer Cap
36	1	Screw
37	8	Cover
38	2	Back Casing
39	1	Capacitor Holder
40	2	Screw
41	2	Tie
42	1	Capacitor
43	4	Spring Washer
44	4	Bolt Housing

5. TROUBLE-SHOOTING

Table 3: Troubleshooting

PROBLEM	POSSIBLE CAUSE	SOLUTION
Pump will not start	No main power supply	Check main power
	Low voltage	Check voltage
	Capacitor defective	Check capacitor, replace if necessary
	Full vacuum in piping	Install a vacuum break valve system or order pump with re-start movement
	Motor defective	Return to factory for repair
	Thermal protector switch on	Wait for pump to cool down, pump will re-start automatically
Pump does not reach ultimate pressure	Pipes, hoses, or connection leaking	Check and seal or replace
	Inlet filter or exhaust is dirty	Clean filter cartridge or replace filter if necessary
	Cylinder or cup seal defective	Replace cylinder or cup seal
	Plate valve defective	Replace plate valve
	Vacuum gauge defective	Use correct size vacuum gauge
	Pump is too small	Utilize larger pump
Pump is excessively noisy	Damaged bearings	Return to factory for repair
	Plate valve defective	Replace plate valve
	Cylinder or cup seal defective	Replace cylinder or cup seal
	Vibration being transferred to enclosure	Use suitable anti-vibration mounting
Pump gets too hot	Cooling air supply is obstructed	Set pump up correctly
	Ambient temperature is too high	Set pump up correctly
	Process air is too hot	Change the process