

## Dry Vacuum Pumps With Low Ultimate Pressures



- OEM Design
- High pumping speed even below 15 Torr
- Compact/Small footprint
- Continuous dry oil-free pumping
- Cost effective
- Easy maintenance
- Quiet

### Model 8111

**A High Performing Small Package for OEM Applications**

### Model 2581

**Small Footprint For a 100 L/min Dry Pump**

Dry Vacuum pump Model 8111 delivers incredible performance (1.5 Torr Ultimate Pressure) in a very small package. Using forced valve operation (patent pending) and minimal dead space, exceptional performance in a 2-stage diaphragm is achieved.

With a free air displacement of 36 L/min (at 60Hz) and high pumping speed below 15 Torr, this pump is extremely compact (less than 382 in<sup>3</sup>) and is very economical compared to other 3 and 4-stage diaphragm pumps.

This innovative pump is designed as a backing pump for hybrid turbos and MDPs used on small chamber applications and analyzers.

Welch's next generation WOB-L® piston pump delivers <4 Torr and 100 L/min with only a 12.5x7.6 inch footprint. Simplicity is the key to the economical aluminum design. As piston wobbles, air resistance on the upward stroke expands Teflon® seal on piston to increase its efficiency while compensating for the wobble action.

The vacuum pump is ideal for backing hybrid turbo and molecular drag pumps and also where quick roughing of a chamber is needed. Its pumping speed curve is shaped like that of an oil-seal rotary vane pump. This key feature makes the 2581 ideal for economically replacing oil-seal rotary vane pumps of similar size to back hybrid turbo and molecular drag pumps.

# Welch vacuum

A Thomas Industries Company

# Specifications and Ordering Information

| Welch Model                                | 8111                          | 2581                            |
|--|-------------------------------|---------------------------------|
| Free Air Displacement, L/min@60Hz (50Hz)   | 35(30)                        | 100 (83)                        |
| Ultimate Pressure, Torr(mbar)              | 1.5(2)                        | <4(<5.3)                        |
| Mechanism                                  | Diaphragm                     | Wob-I Piston                    |
| Motor HP(Watts)                            | 1/6(110)                      | 1/3                             |
| Motor Type                                 | IP00                          | IP20                            |
| Tubing Needed I.D. In. (mm)                | 1/4 (7)                       | 3/8 (9.5)                       |
| Weight, lbs.(kg)                           | 13(5.9)                       | 22.5(10.3)                      |
| Shipping Weight, lbs (kg)                  | 22 (9.9)                      | 30 (13.6)                       |
| Dimensions(LxWxH) in.(mm)                  | 10.25x5x7.24<br>(261x127x189) | 13.25x7.6x11.7<br>(336x193x297) |
| <b>Cat. Number</b>                         |                               |                                 |
| 115V, 60Hz 1Ph w/hose barb                 | 8111B-01                      |                                 |
| 230V, 50Hz, 1Ph w/hose barb <sup>1</sup>   | 8111C-02                      |                                 |
| 115V, 60Hz 1Ph w/NW flange <sup>2</sup>    | 8111B-24                      | 2581B-24                        |
| 230V, 50Hz, 1Ph w/NW flange <sup>1,2</sup> | 8111C-24                      | 2581C-24                        |
| <b>Service Kit</b>                         | 8111K-01                      | 2581K-01                        |

\*Technical Specifications Subject to Revision

1. \*50Hz units come with CE marking.
2. 8111 comes with NW16 flange and 2581 comes with NW25 flange with 3/8" NPT for hose barb

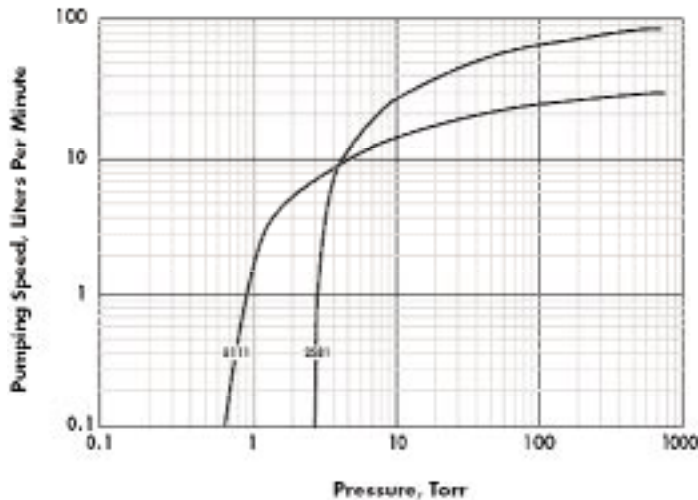

Note: Pumping Speed Curves at 60Hz (16% less for 50Hz)

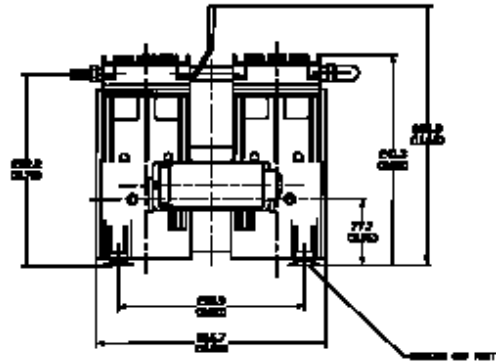
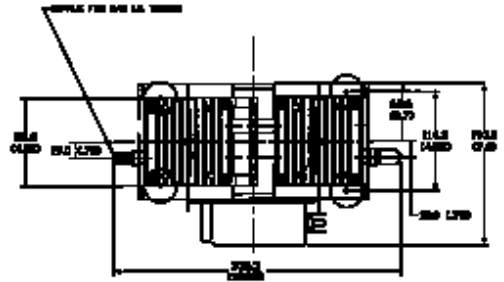

Model 2581B-01

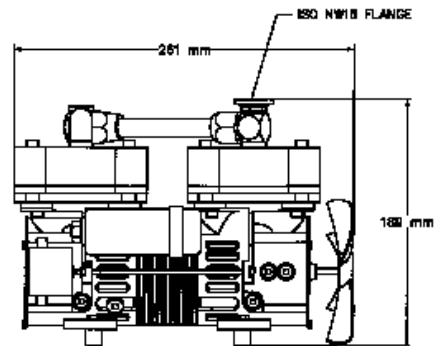
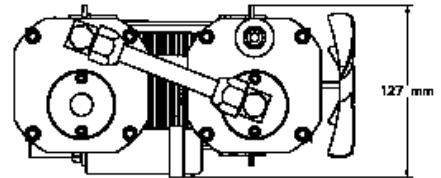

Model 8111B-24

**Welch  
vacuum**

A Thomas Industries Company

Welch Vacuum, Thomas Industries Inc.  
7300 N. Linder Ave.  
Skokie, IL 60077

Phone: (847) 676-8800 Ext. 1 • Fax: (847) 677-8606

Email: [welchvacuum@thomasind.com](mailto:welchvacuum@thomasind.com)

For more information, see the Welch® Web Catalog at:  
[www.welchvacuum.com](http://www.welchvacuum.com)

Welch is a registered trademark of Welch Vacuum, Thomas Industries Inc.  
WOB-L is a trademark of Thomas Industries Inc.