

DuraVane

Oil-free rotary vane pumps
RVD002L

DuraVane oil-free rotary vane pumps are heavy-duty compact motor-mounted units, extremely reliable for many industrial applications. The pump can also operate as a low pressure compressor.

- Heavy duty construction.
- Compact design, small footprint.
- High-tech vane material provides long vane life.
- Low noise level.
- Low maintenance.
- Air-cooled design.
- Direct drive.
- Simple to install.



Performance characteristics

Displacement: 2CFM
 Final vacuum: 26.4"Hg(90Torr)
 Motor: 0.25HP/60HzTEFC
 Voltage: 110V/1phase
 Speed: 3400RPM
 Noise level(at 3ft): 62dBA
 Weight: 12Lbs
 Inlet conn.: 3/8" hose
 Discharge conn.: -

Can operate as a compressor up to 10 psig.

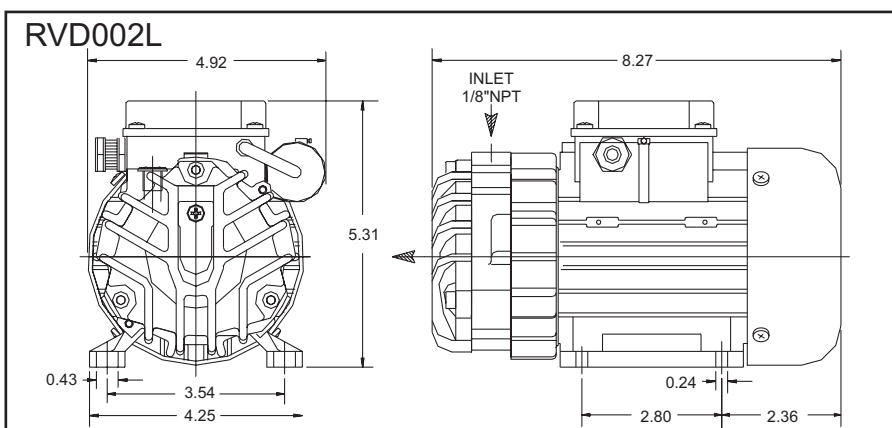
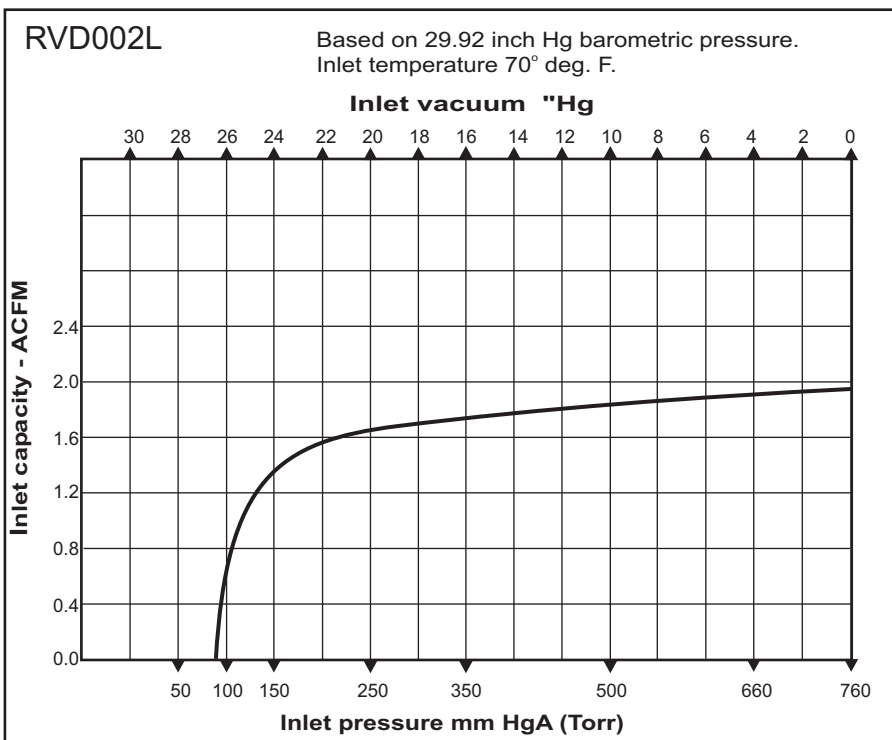

Information contained in this document is for reference only. Subject to change without notice.