

DuraVane

Oil-free rotary vane pumps
RVD004L

DuraVane oil-free rotary vane pumps are heavy-duty compact motor-mounted units, extremely reliable for many industrial applications. The pump can also operate as a low pressure compressor.

- Heavy duty construction.
- Compact design, small footprint.
- High-tech vane material provides long vane life.
- Low noise level.
- Low maintenance.
- Air-cooled design.
- Direct drive.
- Simple to install.



Performance characteristics

Displacement: 4.2CFM
 Final vacuum: 26.4"Hg(90Torr)
 Motor: 0.4HP/60HzTEFC
 Voltage: 110V/1phase
 Speed: 3400RPM
 Noise level(at 3ft): 62dBA
 Weight: 19lbs
 Inlet conn.: 1/4"NPT
 Discharge conn.: 1/2"NPT
 (exhaust silencer is standard)

Can operate as a compressor up to 10 psig.

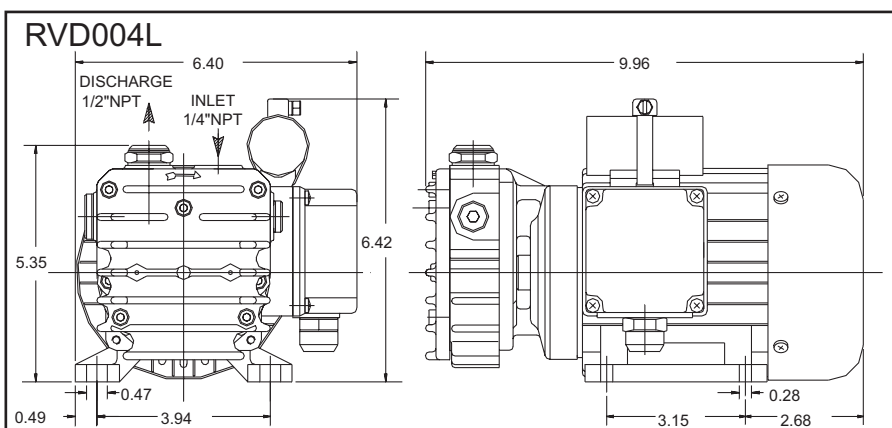
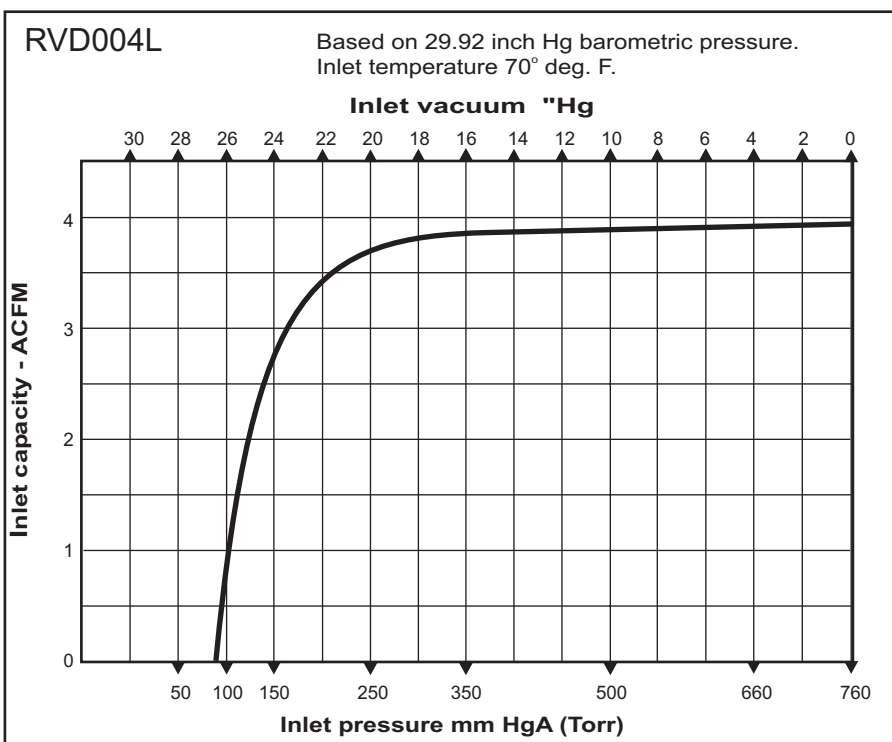

Information contained in this document is for reference only. Subject to change without notice.