

### DuraVane

Oil-free rotary vane pumps  
RVD018L

**DuraVane** oil-free rotary vane pumps are heavy-duty compact motor-mounted units, extremely reliable for many industrial applications. Efficient cooling is ensured by a powerful centrifugal fan. The pump can also operate as a low pressure compressor.



#### Performance characteristics

Displacement: 18CFM  
 Final vacuum: 26.4"Hg(90Torr)  
 Motor: 1.25HP/60HzTEFC  
 Voltage: 110V/1phase  
 208/230/460V/3phase  
 Speed: 1800RPM  
 Noise level(at 3ft): 68dBA  
 Weight: 63Lbs  
 Inlet conn.: 3/4"NPT  
 Discharge conn.: 1/2"NPT  
 (exhaust silencer is standard)

*Can operate as a compressor up to 8.5 psig.*

- Heavy duty construction.
- Compact design, small footprint.
- High-tech vane material provides long vane life.
- Low noise level.
- Low maintenance.
- Air-cooled design.
- Direct drive.
- Simple to install.

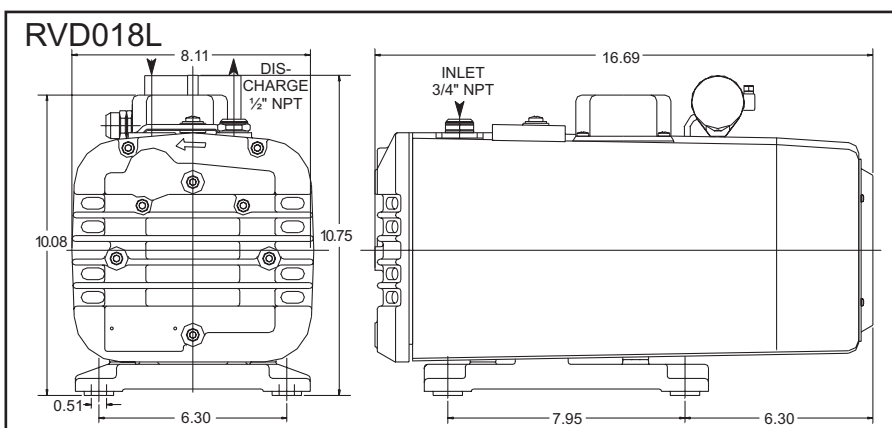
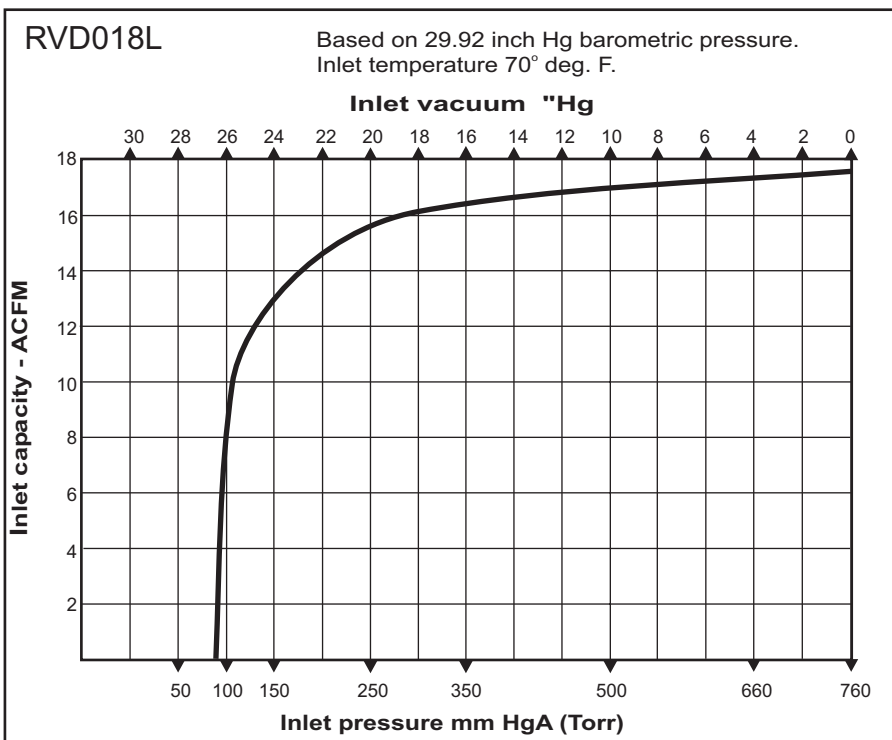

Information contained in this document is for reference only. Subject to change without notice.