

DuraVane

Oil-free rotary vane pumps
RVD060L

DuraVane oil-free rotary vane pumps are heavy-duty compact motor-mounted units, extremely reliable for many industrial applications. Efficient cooling is ensured by a powerful centrifugal fan. The pump can also operate as a low pressure compressor.



Performance characteristics

Displacement:	56CFM
Final vacuum:	26.4"Hg(90Torr)
Motor:	5HP/60HzTEFC
Voltage:	208/230/460V/3phase
Speed:	1800RPM
Noise level(at 3ft):	74dBA
Weight:	167Lbs
Inlet conn.:	1"NPT
Discharge conn.:	-

(exhaust silencer is standard)

- Fewer vanes than other oil-free rotary vane vacuum pumps.
- High-tech, self-lubricating graphite composite vane material.
- Longer vane life and less vane replacement.
- Heavy duty construction.
- Compact design, small footprint.
- Low noise level.
- Air-cooled design.
- Direct drive.
- Simple to install.

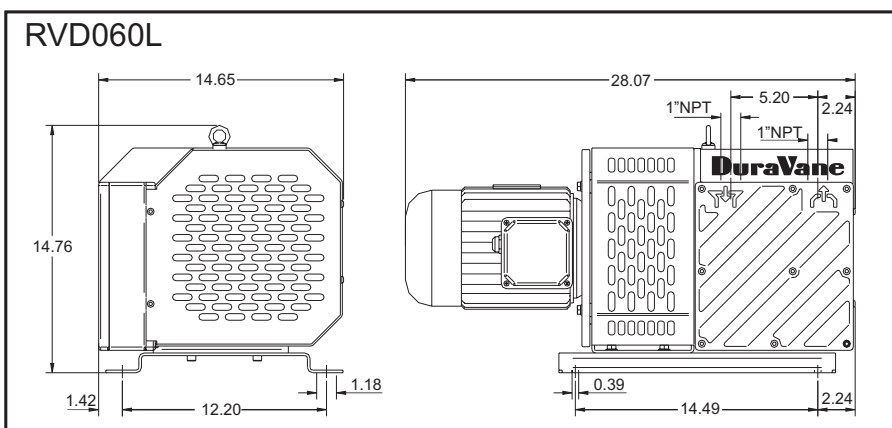
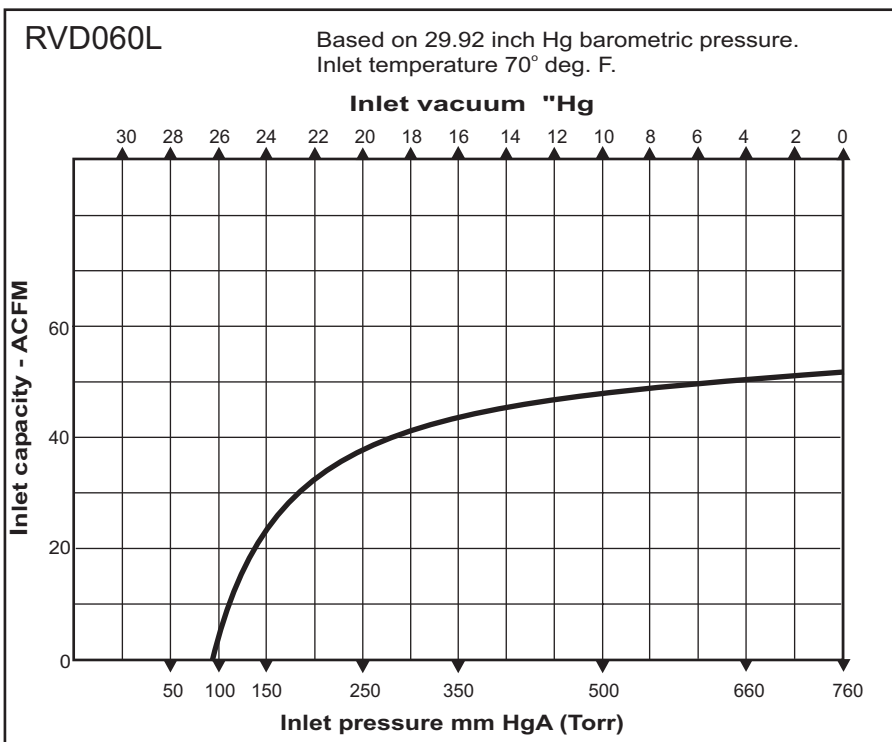

Information contained in this document is for reference only. Subject to change without notice.